

HOUTTUIN 216 SERIES PUMPS

TWO-SCREW PUMPS STANDARD PRODUCT SPECIFICATIONS

PRODUCT PERFORMANCE YOU CAN RELY ON

The 216 series provides customers a time-tested, globally adopted self-priming two screw pump suitable for low pressure applications for both clean and abrasive fluids. The 216 offers:

- 60+ years of global, field proven reliability
- Non-contacting rotors for abrasives handling
- Field replaceable liner and 'pop-out' rotor access for ease of inspection and maintenance
- Optional, mounted relief valve for overpressure protection

The 216 is suitable for a host of duties within process and transport applications for the chemical, food and beverage, oil and gas, petrochemical, power, shipbuilding and other general industries. It is available in a variety of materials, including cast and stainless steel, to meet your specific requirements.



216 SERIES TWO-SCREW PUMP

Up to 1,100 m³/h, 16 barg and viscosities from 0.6 cst

PRODUCT SPECIFICATIONS AND FEATURES

Casing and Covers	Ductile iron, cast iron, carbon or stainless steel, bronze, Ni-resist
Rotors	Carbon or Stainless Steel (Type 300 or 400) (with optional hardening and plating)
Liner	Ductile iron, cast iron, Ni-resist, bronze
O-rings	Viton steel or teflon
Shaft Sealing	Stuffing boxes, lip seals, single or double mechanical seals
Timing Gears	Spur
Bearings	Roller - internal or external
Flow rate range	Up to 1,100 m ³ /s (4,840 gpm)
Outlet pressure	Up to 16 barg (230 psi)
Inlet pressure	Up to 10 barg (145 psi)
Viscosity	0.6 - 1,500 cSt
Temperature	-5° C to 100° C (-20° F - 212° F)
Speed	Up to 2900 rpms
Drive	Direct, suitable for variable speed operations
Rotation	Clockwise
Mounting	Horizontal
Port Connections	Per ANSI 150#, 300#, 600# or DIN PN16, PN24
Accessories	Pressure relief valve, temperature and vibration monitors

APPROXIMATE STANDARD DIMENSIONS

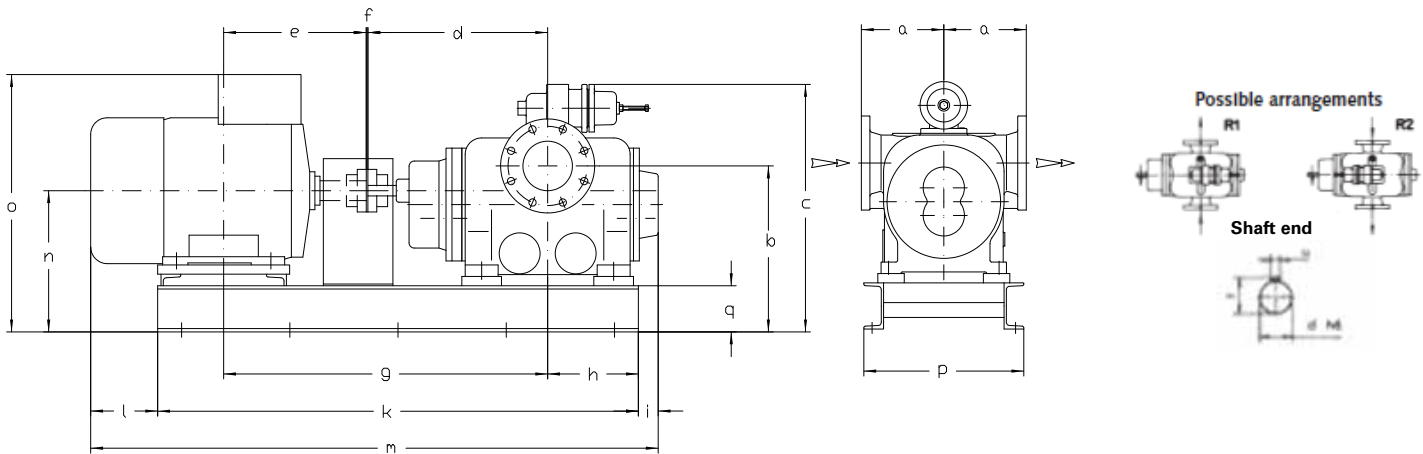

PUMP SIZE	PUMP DIMENSIONS															SHAFT END					RELIEF VALVE SIZE
	B	C	D	E	F	G	H	I	K	L	M	N	O	Q	Q	D	L	T	U		
088	448	622	455	370.5	5	830.5	230	57	1255	138	1450	373	600	120	455	28	60	31	8	46	
105	478	666	485	432	5	922	255	57	1415	103	1575	413	735	140	485	28	60	31	8	46	
118	523	774	545	482.5	5	1032.5	275	60	1555	145	1760	448	795	160	545	32	80	35	10	70	
135	562	834	582	539.5	5	1125.5	310	63	1710	247	2020	487	940	180	581	38	80	41	10	70	
150	628	1025	677	589	5	1271	375	55	1980	200	2235	543	1050	200	677	42	110	45	12	100	
165	653	1042	736	614.5	5	1355.5	395	82	2075	188	2345	563	1070	200	736	45	110	48.5	14	100	
180	693	1112	775	640	5	1420	425	80	2175	325	2580	583	1090	200	775	50	110	53.5	14	100	
195	728	1191	800	744	5	1549	420	93	2310	357	2760	623	1188	220	800	55	110	59	16	135	
210	788	1249	870	779	5	1654	440	95	2470	370	2935	663	1228	240	870	60	140	64	18	135	
225	808	1298	890	779	5	1674	445	100	2495	370	2965	683	1248	240	890	65	140	69	18	135	

PUMP SIZE	PUMP FOOT DIMENSIONS								FLANGES		MOTOR		
	A	B	C	D	F	M	N	S	DN	B	KW	RPM	FRAME
088	325	310	35	415	350	90	60	4x18	100	228	22	1480	180L
105	370	330	35	460	370	90	60	4x18	125	254	37	1480	225S
118	400	335	35	500	380	100	60	4x22	150	285	55	1480	250M
135	480	400	40	570	450	100	70	4x22	200	340	90	1480	280M
150	580	450	40	670	500	100	70	4x22	250	405	110	1480	315S
165	620	490	45	740	550	120	90	4x26	250	405	160	1480	315M
180	670	540	45	790	600	120	90	4x26	300	460	200	1480	315L
195	680	590	45	800	650	120	90	4x26	300	460	250	1480	355M
210	690	600	45	840	660	150	120	4x26	300	460	315	1480	355L
225	700	660	45	850	720	150	120	4x26	350	520	355	1480	355L

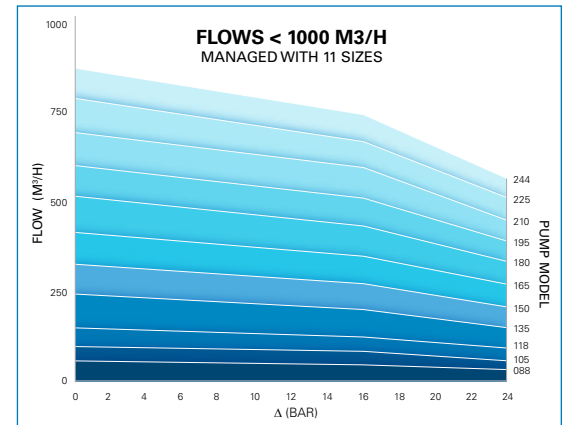

TYPICAL FLUIDS

- Fuel Oils
 - Light
 - Heavy
- Hydraulic Oils
- Lube Oils
- Water
- Seawater
- Crude Oil
- Light Products

SAMPLE APPLICATIONS

- Bilge/Ballast Pumps
- Cargo Pumps
- General Service
- Pipeline Transport
- Transfer Pumps
- Loading & Unloading
- Fuel Forwarding
- Lube Oil Pumps
- Hydraulic System Pumps

ADVANTAGES

- **API Pump:** high API 676 3rd edition compliance
- **High Efficiency:** Unique rotor profiles to reduce fluid slip. Robust, oil lubricated bearings require little to no maintenance
- **Easy Maintenance:** simplify inspections and maintenance with easy 'pop-out' rotor design
- **Customization:** optimally balance performance and costs with custom rotor pitches and profiles, seal types and suction/discharge locations
- **Rugged Design:** deliver consistent performance in harsh environmental with often drastic fluctuations in ambient or application conditions
- **Wear Protection:** limit pump wear with corrosion resistant materials, component hardening and specialized coatings
- **Low NPSH:** limit NPSHr with a free-flow suction flow path and field proven flow geometries
- **Bearings:** limit maintenance with oil lubricated, maintenance free ball bearings that provide dual radial and axial rotor support
- **Gears:** transmit torque safely with specialty hardened and ground oil-lubricated timing gears
- **PRV:** simplify installation and protect from pressure spikes with an integral pressure relief valve

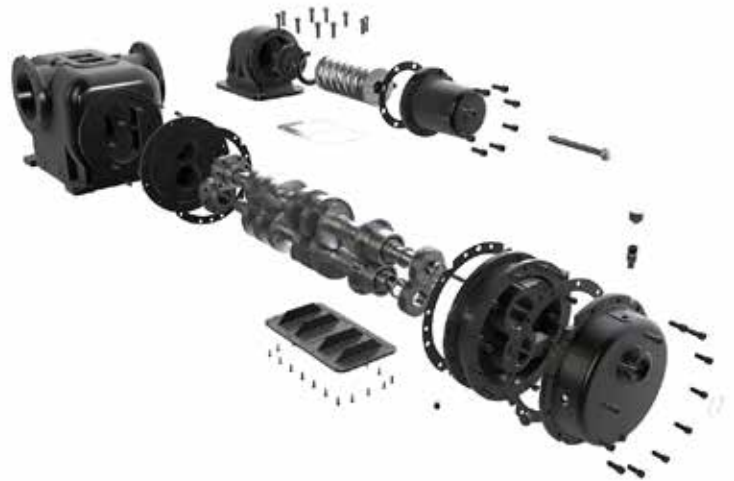

CIRCOR Fluid Handling

1710 Airport Road
 Monroe, NC 28110-5020
 Tel: +1.704.289.6511
 Tol: +1.877.853.7867

Oil & Gas Products & Services

ALLWEILER® HOUTTUIN™ IMO® ROSSCOR® WARREN®

CIRCOR, ALLWEILER, HOUTTUIN, IMO, ROSSCOR, and WARREN are registered trademarks of the CIRCOR or its subsidiaries in the U.S. and/or other countries. © 2018 CIRCOR International. All rights reserved.
 GB-OG021-HT216-03/18

CIRCOR

HOUTTUIN™